



Scots Bonnet

Le groupe de danse écossaise Scots Bonnet de Saint Quay Perros organise les **vendredi 30 juin, samedi 1er et dimanche 2 juillet 2023** leur bal.

- Détails d'organisation : <https://www.scots-bonnet.fr/fr/bal-2023/organisation-du-bal>
- Inscription : <https://www.scots-bonnet.fr/fr/bal-2023/inscription-au-bal>

1 EH3 7AF J32 · 3/4L

Roy Goldring: RSCDS XL 6 · Crib: E-cribs · Diagram: Keith Rose's Diagrams

- 1- 1c lead down the middle and up, on [8]
2c+3c step in for
- 9- 1c+2c+3c Promenade, at end 1c cast off (to 2,1,3)
- 17- 1c cross Rsh | turn 1cnr RH ; cross up/dn Rsh | turn 2cnr RH (2,1x,3) |
- 25- 2c+1M & 1W+3c RHA ; 1c ½Fig 8 Rsh round 4cnr (2,1,3)

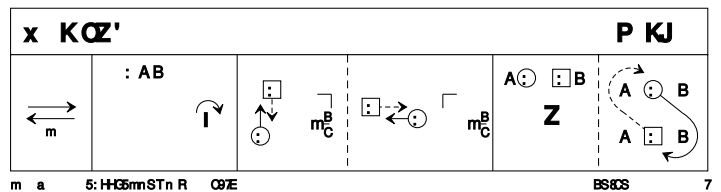

2 THE IRISH ROVER R32 · 3/4L

James B Cosh: Twenty Two SCD · Crib: E-cribs · Diagram: Keith Rose's Diagrams

- 1- 1c dance through 3c (2c up) and cast up ; 2c+1W & 1M+3c RHA, 1c finish facing 1cnrs.
- 9- 1c+1cnrs ½Reel4, pass Lsh ; ½Reel4 with 2cnrs, fast ¾ LH turn in the centre
- 17- 1W+3c (at top) & 1M+2c Reels3 across (Lsh to 1cnr pos), (to 3x,1,2x)
- 25- diagonal R&L (1M down,1W up) (2,1,3)

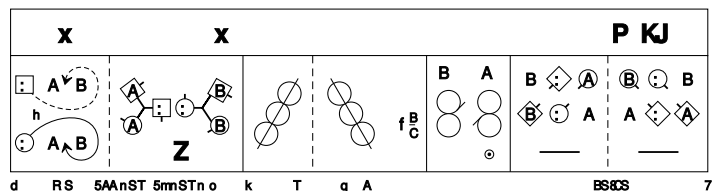

3 CHERRYBANK GARDENS S32 · 3/3L

John Drewry: Thirty Popular Dances, Volume Two · Crib: E-cribs · Diagram: Keith Rose's Diagrams

- 1- 1c+2c set | Petronella in tandem ; repeat (2x,1x,3)
- 9- 2c+1c set | 2c cross RH **while{2}** 1c turn LH ¾ ; 2c+1W & 1M+3c RHA (Teapots) to sidelines (2,1,3)
- 17- 1c+3c S&Link ; 3c+1c Circle4 left, end 3c facing 1c for
- 25- Gr-Chain (2c cross to start) (2, 3, 1)

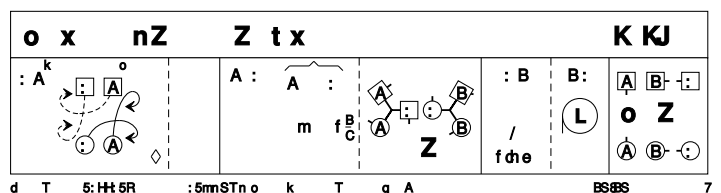

4 FOLLOW ME HOME J32 · 3/4L

Ellie Briscoe: RSCDS XXXVIII 3 · Crib: E-cribs · Diagram: Keith Rose's Diagrams

- 1- 1c set | cross RH ; cast off (2c up) | turn $\frac{3}{4}$ LH
- 9- BiL with 1cnrs | $\frac{1}{2}$ turn 1cnrs RH ; 1c followed by 1cnrs chase clw round 4cnrs to leave 1cnrs in exchanged places, and join LH to 2cnr, RH to P
- 17- BiL with 2cnrs | $\frac{1}{2}$ turn 2cnrs LH ; 1c followed by 2cnrs chase cclw, 1c crossing Lsh to 2plx facing out (3x,1x,2x)
- 25- $\frac{1}{2}$ Lsh Reels3 on the sidelines ; All set and cross (2,1,3)

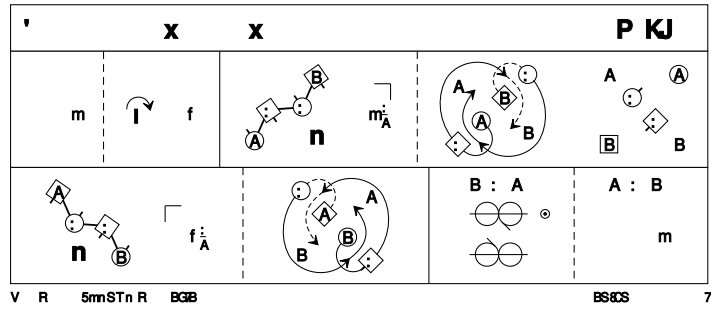

5 POLHARROW BURN R32 · 5/5L

Hugh Foss: Magazine Dances 2005-2009 · Crib: E-cribs · Diagram: Keith Rose's Diagrams

- 1- 1c & 3c cross | cast off (2c & 4c up) ; $\frac{1}{2}$ Fig8 up round 2c/4c (2,1,4,3,5)
- 9- 1c & 3c turn P RH ; turn P LH to face 1cnrs **while(8)** 2c & 5c cross RH and chase clw to other end of set, 2M & 5W leading P (5,1,4,3,2)
- 17- 1c & 3c diag. $\frac{1}{2}$ Reels4 with 1cnrs (1diags), pass Lsh ; repeat on 2diags
- 25- Repeat with 3cnrs (1diags) ; 1c & 3c turn LH | cast off on own side (4c & 5c up) to (2,4,1,5,3)

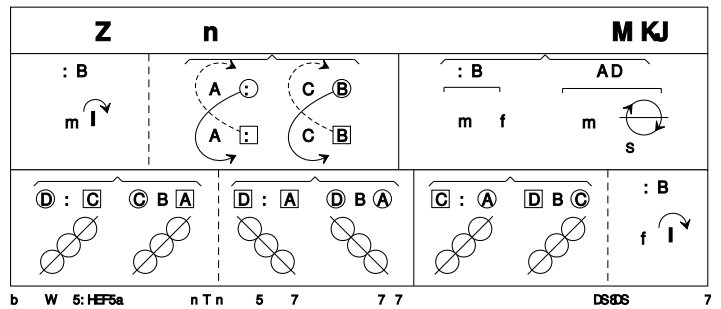

6 GEBURTSTAG IN WIEN S32 · 3/4L

David I Hall · Crib: E-cribs · Diagram: Heiko's Diagrams

- 1- All set | cross RH ; Circle6 L $\frac{1}{2}$ (3,2,1)
- 9- 2c+1c The Knot (3,1,2)
- 17- 3C S&Link ; all set in lines3 across | 2c & 3c set **while** 1c Petronella Turn to 2pl (2,1,3)
- 25- 2c+1c Pousette

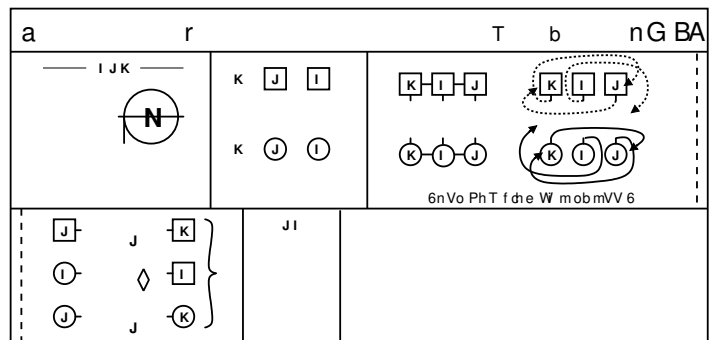

7 HOOPER'S JIG J32 · 3/4L

Miss Milligan's Miscellany of Scottish Country Dances · Crib: E-cribs · Diagram: Keith Rose's Diagrams

- 1- All clap, 1c cross Rsh and cast off one (2c up) ; 1c+3c RHA
- 9- All clap, 1c cross back Rsh, cast up to own place (2c down) ; 1c+2c LHA
- 17- 1M+3W change places RH | 1W+3M change RH, **while{2}** 1M+3W dance a Rsh loop ; 1M+3W cross back RH **while{2}** 1W+3M loop | 1W+3M cross back LH, 1W to 2pl **while{2}** 1M casts to 2pl (2c up)
- 25- 2c+1c R&L

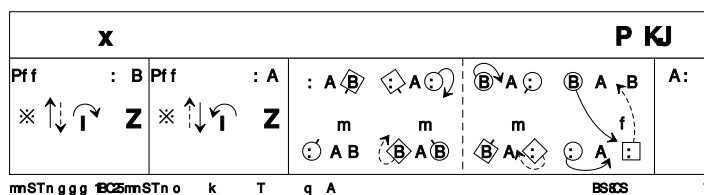

8 THE COUNTESS OF DUNMORE'S REEL R32 · 3/4L

Deirdre MacCuish Bark: RSCDS XLIX 12 · Crib: E-cribs · Diagram: Keith Rose's Diagrams

- 1- 1c set | dance down (2c up) ; cast up round 3c | set advancing to face 1cnr
- 9- 1c turn 1cnr RH, pass Rsh; turn 2cns RH, pass Rsh to face out in 2pl (cnrs dance for {4}) (2,1,3)
- 17- [3C Chain Progression] 1c cast ¼ clw round set **while** 2c & 3c Turn RH ¾ | 2M+3W turn LH 1½ **while{4}** the others promenade clw ½ round set | 3c+2c turn RH ¾ **while** 1c dance clw to 2pl (3,1,2)
- 25- all chase ½ way clw ; set | cross RH (2,1,3)

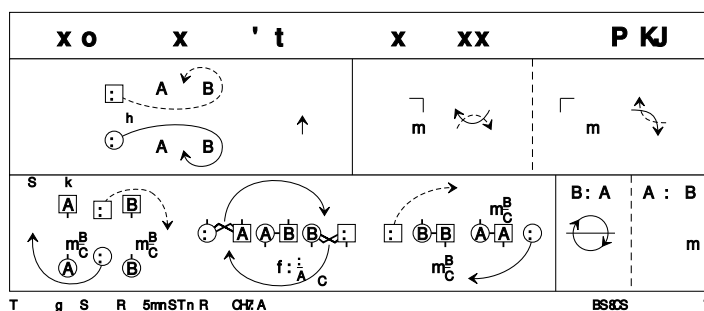

3C Chain Progression was earlier known as Chaperoned Chain Progression

9 JEAN MARTIN OF ABERDEEN S32 · 3/3L

Muriel A Johnstone: Magazine Dances 2005-2009 · Crib: E-cribs · Diagram: Keith Rose's Diagrams

- 1- 1c Turn RH, cast (2c up) ; All circle6 L ¾ into lines across (W facing down, M up)
- 9- All set | change places RH with P ; All circle6 L left ¾ and end in middle facing up (3,1,2) for
- 17- Allemande (2,1,3)
- 25- 1c+3c Bourrel : 1M+3W set adv. | Turn BH ¾ & twirl to end BtoB in middle, 3W facing up & 1M down **while{4}** 1W+3M chase cclw to face P ; set to P | Turn BH ¾ to (2,3,1)

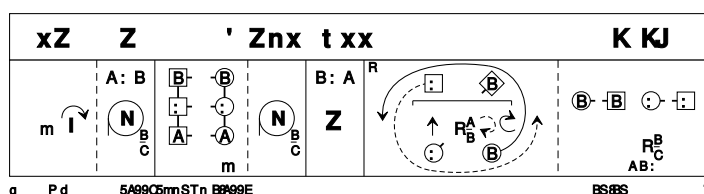

10 A JIG SO PUZZLED J32 · 3/4L

Mathias Ferber: *The Paris Book of Scottish Country Dances, volume 2* · Crib: E-cribs · Diagram: Keith Rose's Diagrams

- 1- 1c set | cross down RH ; cast off behind 3c | dance up NHJ to 2pl centre facing opposite sides (2c up on [7-8])
- 9- 1c 6 bars of DTr **while(6)** 2c & 3c set | cross RH ; set | 1c dance RSh round 3cnrs[pos] into facing lines3 across **while(2)** 2c & 3c cross RH
- 17- 3C S&Link (2,1,3) ; all turn P RH 1½ (2,1,3)
- 25- Circle6 and back (2,1,3)

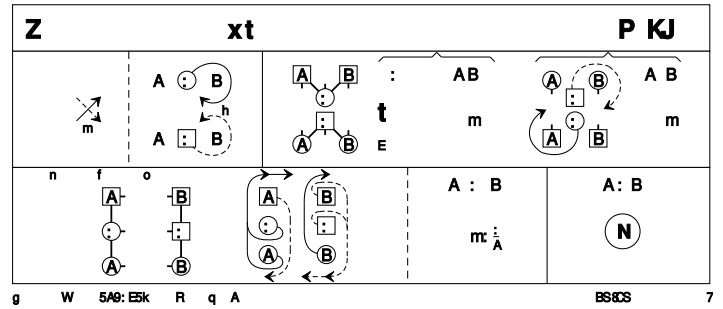

11 BRATACH BANA R32 · 3/4L

John Drewry: *Thirty Popular Dances, Volume Two* · Crib: E-cribs · Diagram: Keith Rose's Diagrams

- 1- 1c turn RH | cast off (2c up) ; ½ Fig8 to R around 1cnr (to 2,1x,3)
- 9- ½Reel3 on sides (Rsh to 2cnr) ; ½Reel3 across (Lsh to 3cnr position), finish on sides (3x,1,2x)
- 17- 1c turn ¾ LH, Turn 1cnr person (3cnr position) RH ; pass Rsh, turn 2cnr person (4cnr position) ¾ RH to promhold (cnr on the right)
- 25- These pairs change places Rsh | drop LH and turn RH ½ to sidelines ; half diagonal R&L (1st diagonal direction)

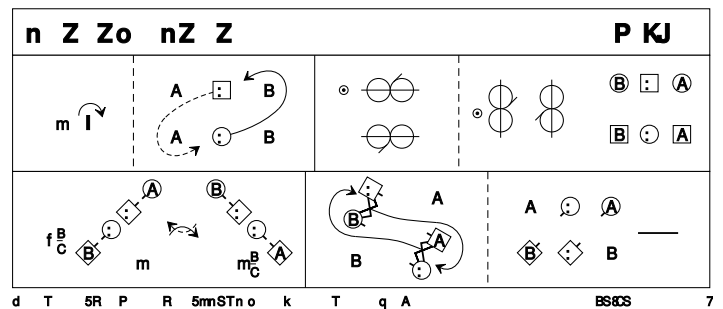

Note: [27-28] was originally 2 PdB in promhold.

12 THE BON VIVEUR M64 · 4S

Ian Brockbank: *RSCDS LII 11* · Crib: E-cribs · Diagram: Keith Rose's Diagrams

- 1- Circle8 and back
- 9- 1c+3c Men's Chain
- 17-28 12 bars of Schiehallion reel (4,1,2,3)
- 29-32 All Birl or Turn P RH (4,1,2,3)

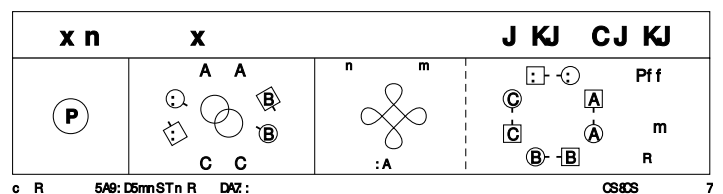

----- BREAK -----

13 CITY LIGHTS J32 · 3/4L

Nicola Scott: RSCDS LII 1 · Crib: E-cribs · Diagram: Keith Rose's Diagrams

- 1- 1c turn RH | cast (2c up) ; turn LH $1\frac{1}{4}$ to face 1cnrs (2,1,3)
- 9- "Corners Pass And Allemande Turn R" on 1diag [same figure as Corners Pass And Turn, except that cnrs dance an Allemande Turn to the Right and 1c meet P in centre at end] ; all cnrs chase clw $\frac{1}{2}$ **while{4}** 1c turn LH $1\frac{1}{4}$ to face 2cnrs[pos] (3x,1,2x)
- 17- Repeat [9-12] on 2diag ; repeat [13-16], 1c finish in centre Lsh to P facing opposite side (2,1,3)
- 25- 1W+2c & 1M+3c RHA (to 2,1,3) ; all turn P RH (or birl) (2,1,3)

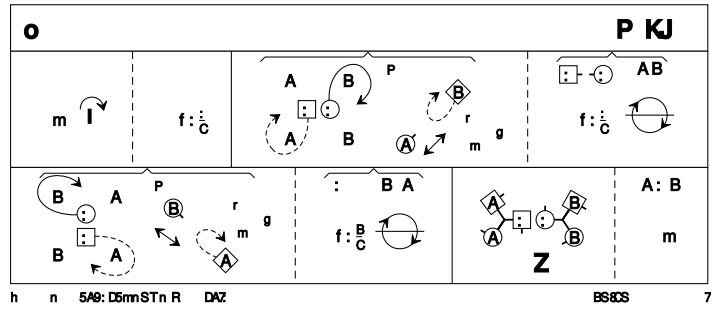

14 OUT OF THIN AIR S32 · 3/3L

Sue Porter and Di Rooney: A Third Book of Graded Scottish Country Dances · Crib: E-cribs · Diagram: Keith Rose's Diagrams

- 1- 1c set | cross RH ; cast (2c up) | turn LH to face 1cnrs
- 9- Turn CPCP, finish in 2pl middle facing up NHJ
- 17- 1c dance up between 2c | cast to 2pl ; dance down between 3c | cast to 2pl (2,1,3)
- 25- 1c+3c Tournée

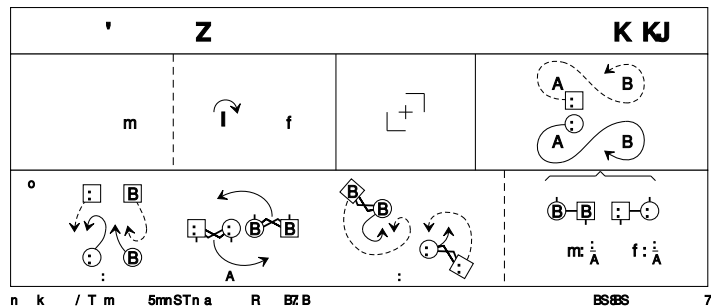

15 THE CLANSMAN R32 · 2/4L

Derek Haynes: RSCDS XXXII 8 · Crib: E-cribs · Diagram: Keith Rose's Diagrams

- 1- 1c cross RH | cast off (2c up) ; 2c+1c $\frac{1}{2}$ RHA | set to P (1,2x)
- 9- 1c+2c R&L, finish with $\frac{3}{4}$ LH turn into line across, the W in the centre:
- 17- The Targe (1W+2W turn $\frac{3}{4}$ RH **while{2}** 1M+2M chase $\frac{1}{4}$ round cclw | 1M+2W & 1W+2M Turn LH ; repeat) finishing on sides (2,1x)
- 25- 2c facing 1c set | all set to P ; 1c lead up, cross and cast to 2pl (2,1)

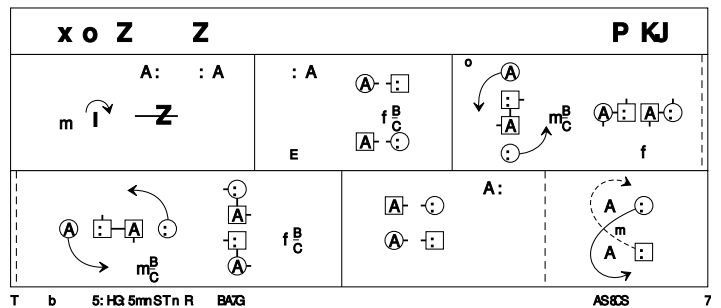

16 THE COMPLEAT GARDENER J32 · 3/4L

Irene Paterson: A Third Book of Graded Scottish Country Dances · Crib: E-cribs · Diagram: Keith Rose's Diagrams

- 1- 1c+2c Set&Rotate (2,1,3)
- 9- 1c cross RH | cast R round 1cnr ; cross up/dn LH | cast L to face 1cnr
- 17- 1c+1cnrs corners pass and turn, pass Rsh ; repeat with 2cnrs, to own side
- 25- Circle6 and back (2,1,3)

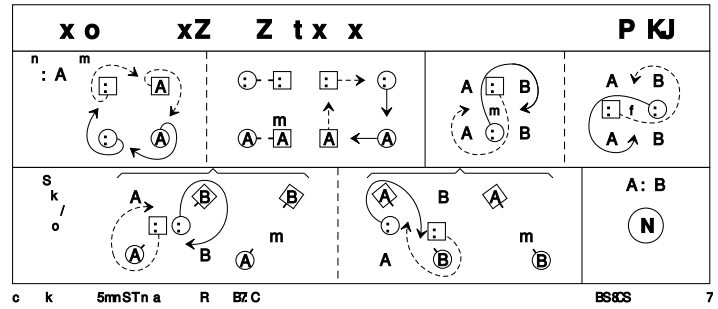

17 SHALL WE DANCE? S32 · 3/3L

Isabel Monteiro · Crib: E-cribs

- 1- 1c turn BH | dance down below 3c ; cast up (2c up) | turn LH to centre line, W above M
- 9- 2c+1W & 1M+3c circle3 to L & 1c twirl to face P, 2c/3c face down/up NHJ ; all set | 1c petronella to opp side **while** 2c & 3c turn inwards & cast to sides (2,1x,3)
- 17- All set | 1c "gypsy" turn RSh ; 1M followed by 1W cast off, dance across & face up (3c up)
- 25- Modified Grand Chain, 2c start by crossing. On [3-4] all ½ turn RH & twirl away then continue the chain as usual (2,3,1)

18 THE REEL OF THE ROYAL SCOTS R32 · 3/4L

Roy Goldring: The Leaflet Dances with Music · Crib: E-cribs · Diagram: Keith Rose's Diagrams

- 1- 1W+2W (1M+2M) turn LH (RH) ½, finishing 1c BtoB in 2pl | All set as in DTr ; 1W+3W (1M+3M) turn RH (LH) ½ | 2c+3c+1c set as in DTr
- 9- 1c followed by 3c dance up between 2c, cast off ; dance NHJ down through 3pl, cast up to face 1cnrs, 3c looping into 3pl
- 17- 1c turn 1cnrs RH, pass Rsh (cnrs dance for {4}) ; turn 2cnrs RH (same), and cross Rsh to (2,1,3)
- 25- All circle6 and back

